

INSTRUCTION MANUAL

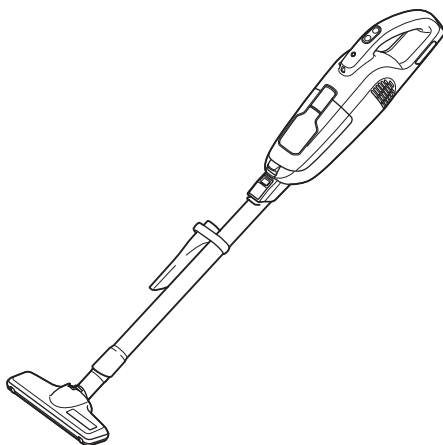

Cordless Cleaner

CL114FD



Read before use.

WARNING

- This appliance can be used by children aged from 8 years and above and persons with reduced physical, sensory or mental capabilities or lack of experience and knowledge if they have been given supervision or instruction concerning use of the appliance in a safe way and understand the hazards involved.
- Children shall not play with the appliance. Cleaning and user maintenance shall not be made by children without supervision.
- See the chapter "SPECIFICATIONS" for the type reference of the battery.
- See the sections "Removing built-in battery" and "Installing replacement battery" for how to replace the battery.
- The contained lithium-ion batteries are subject to the Dangerous Goods Legislation requirements. When disposing the battery, remove it from the appliance and dispose of it in a safe place. Follow your local regulations relating to disposal of battery.
- Under abusive conditions, liquid may be ejected from the battery; avoid contact. If contact accidentally occurs, flush with water.
- If electrolyte gets into your eyes, rinse them out with clear water and seek medical attention right away. It may result in loss of your eyesight.
- See the chapter "SPECIFICATIONS" for the type reference of the charger. For the purposes of recharging the battery, only use the charger provided with the appliance.
- See the section "Symbols" for the meaning of the symbols used for the appliance.
- See the chapter "MAINTENANCE" for the appropriate details of precautions during user maintenance.

SPECIFICATIONS

Model:		CL114FD
Capacity	with a dust bag	500 ml
	with a paper filter	330 ml
Continuous use (with battery BL1020V)	3 (Max speed mode)	Approx. 10 min
	2 (High speed mode)	Approx. 18 min
	1 (Normal speed mode)	Approx. 55 min
Overall length	Cleaner body	458 mm
	With extension wand and nozzle	983 mm
Net weight		1.1 kg
Rated voltage		D.C. 10.8 V - 12 V max

- Due to our continuing program of research and development, the specifications herein are subject to change without notice.
- Specifications may differ from country to country.
- The weight does not include accessories.
- For the purposes of recharging the battery, only use the charger provided with the appliance.

Applicable battery cartridge and charger

Battery cartridge	Battery charger	Charging time (hours)
BL1020V	DC1002	2.0

- Charging time varies by temperature (10°C (50°F) – 40°C (104°F)) that battery cartridge is charged at and conditions of the battery cartridge, such as a battery cartridge which is new or has not been used for a long period of time.

⚠ WARNING: Only use the battery cartridges and chargers listed above. Use of any other battery cartridges and chargers may cause injury and/or fire.

Symbols

The followings show the symbols which may be used for the equipment. Be sure that you understand their meaning before use.



Read instruction manual.



Detachable supply unit



Only for EU countries
Due to the presence of hazardous components in the equipment, waste electrical and electronic equipment, accumulators and batteries may have a negative impact on the environment and human health. Do not dispose of electrical and electronic appliances or batteries with household waste! In accordance with the European Directive on waste electrical and electronic equipment and on accumulators and batteries and waste accumulators and batteries, as well as their adaptation to national law, waste electrical equipment, batteries and accumulators should be stored separately and delivered to a separate collection point for municipal waste, operating in accordance with the regulations on environmental protection. This is indicated by the symbol of the crossed-out wheeled bin placed on the equipment.

Intended use

The appliance is intended for collecting dry dust.

SAFETY WARNINGS

Cordless cleaner safety warnings

⚠ WARNING: IMPORTANT! READ CAREFULLY all safety warnings and all instructions BEFORE USE. Failure to follow the warnings and instructions may result in electric shock, fire and/or serious injury.

1. Do not expose to rain. Store indoors.
2. Do not allow to be used as a toy. Close attention is necessary when used by or near children.
3. Use only as described in this manual. Use only manufacturer's recommended attachments.
4. Do not use with damaged battery. If appliance is not working as it should, has been dropped, damaged, left outdoors, or dropped into water, return it to a service center.
5. Do not handle appliance with wet hands.
6. Do not put any object into openings. Do not use with any opening blocked; keep free of dust, lint, hair, and anything that may reduce air flow.
7. Keep hair, loose clothing, fingers, and all parts of body away from openings and moving parts. Turn off all controls before removing the battery.
8. Use extra care when cleaning on stairs.
9. Do not use to pick up flammable or combustible liquids, such as gasoline, or use in areas where they may be present.

11. Use only the charger supplied by the manufacturer to recharge.
12. Do not pick up anything that is burning or smoking, such as cigarettes, matches, or hot ashes.
13. Do not use without dust bag and/or filters in place.
14. Do not charge the battery outdoors.
15. Recharge only with the charger specified by the manufacturer. A charger that is suitable for one type of battery pack may create a risk of fire when used with another battery pack.
16. Use appliances only with specifically designated battery packs. Use of any other battery packs may create a risk of injury and fire.
17. When (the) battery pack is not in use, keep it away from other metal objects, like paper clips, coins, keys, nails, screws or other small metal objects, that can make a connection from one terminal to another.
18. Under abusive conditions, liquid may be ejected from the battery; avoid contact. If contact accidentally occurs, flush with water.
19. Do not use a battery pack or appliance that is damaged or modified. Damaged or modified batteries may exhibit unpredictable behaviour resulting in fire, explosion or risk of injury.
20. Do not expose a battery pack or appliance to fire or excessive temperature. Exposure to fire or temperature above 130 °C may cause explosion.
21. Follow all charging instructions and do not charge the battery pack or appliance outside the temperature range specified in the instructions. Charging improperly or at temperatures outside the specified range may damage the battery and increase the risk of fire.
22. Do not let familiarity gained from frequent use of tools allow you to become complacent and ignore tool safety principles. A careless action can cause severe injury within a fraction of a second.

SAVE THESE INSTRUCTIONS.

ADDITIONAL SAFETY RULES

1. Read this instruction manual and the charger instruction manual carefully before use.
2. Do not pick up the following materials:
 - Hot materials such as lit cigarettes or spark/metal dust generated by grinding/cutting metal
 - Flammable materials such as gasoline, thinner, benzine, kerosene or paint
 - Explosive materials like nitroglycerin
 - Ignitable materials such as Aluminum, zinc, magnesium, titanium, phosphorus or celluloid
 - Wet dirt, water, oil or the like
 - Hard pieces with sharp edges, such as wood chips, metals, stones, glasses, nails, pins or razors
 - Powder to clot such as cement or toner
 - Conductive dust such as metal or carbon
 - Fine particle like concrete dustSuch action may cause fire, injury and/or property damage.

3. Stop operation immediately if you notice anything abnormal.
4. If you drop or strike the cleaner, check it carefully for cracks or damage before operation.
5. Do not charge the cleaner close to dangerous flammable materials such as gasoline, gas, paint or adhesives.
6. Do not charge the cleaner on papers, cloth, carpet, vinyl, etc. This may cause a fire.
7. Do not charge the cleaner in a dusty place.
8. Be sure no one is below when using the cleaner in high locations.
9. Do not bring close to stoves or other heat sources.
10. Do not block the intake hole or vent holes.

SAVE THESE INSTRUCTIONS.

IMPORTANT SAFETY INSTRUCTIONS

FOR BUILT-IN BATTERY

1. Before using built-in battery, read all instructions and cautionary markings on (1) battery charger, (2) battery, and (3) product using battery.
2. Do not disassemble built-in battery.
3. If operating time has become excessively shorter, stop operating immediately. It may result in a risk of overheating, possible burns and even an explosion.
4. If electrolyte gets into your eyes, rinse them out with clear water and seek medical attention right away. It may result in loss of your eyesight.
5. Do not short the built-in battery:
 - (1) Do not touch the terminals with any conductive material.
 - (2) Avoid storing built-in battery in a container with other metal objects such as nails, coins, etc.
 - (3) Do not expose built-in battery to water or rain.
A battery short can cause a large current flow, overheating, possible burns and even a breakdown.
6. Do not store and use the appliance and built-in battery in locations where the temperature may reach or exceed 50 °C (122 °F).
7. Do not incinerate the built-in battery even if it is severely damaged or is completely worn out. The built-in battery can explode in a fire.
8. Be careful not to drop or strike battery.
9. Do not use a damaged built-in battery.
10. The contained lithium-ion batteries are subject to the Dangerous Goods Legislation requirements. When disposing the battery, remove it from the appliance and dispose of it in a safe place. Follow your local regulations relating to disposal of battery.
11. Use the batteries only with the products specified by Makita.

SAVE THESE INSTRUCTIONS.

Tips for maintaining maximum battery life

1. Charge the built-in battery before completely discharged.
Always stop appliance operation and charge the built-in battery when you notice less appliance power.
2. Never recharge a fully charged built-in battery. Overcharging shortens the battery service life.
3. Charge the built-in battery with room temperature at 10°C - 40°C (50°F - 104°F). Let a hot built-in battery cool down before charging it.
4. Charge the built-in battery once in every six months if you do not use the appliance for a long period of time.

FUNCTIONAL DESCRIPTION

CAUTION: Always be sure that the appliance is switched off before adjusting or checking function on the appliance.

Charging the built-in battery

CAUTION: Only use genuine Makita batteries. Use of non-genuine Makita batteries, or batteries that have been altered, may result in the battery bursting causing fires, personal injury and damage. It will also void the Makita warranty for the Makita product and charger.

CAUTION: Always disconnect the charging plug from the cleaner after charging.

CAUTION: Do not leave the charger in the mains after disconnecting the appliance. Small children may put the live plug in their mouth and cause injury.

Charge the cleaner when using it for the first time or uncharged for a long time. Connect the charging plug to the charging connector, then plug in the charger to the power receptacle.

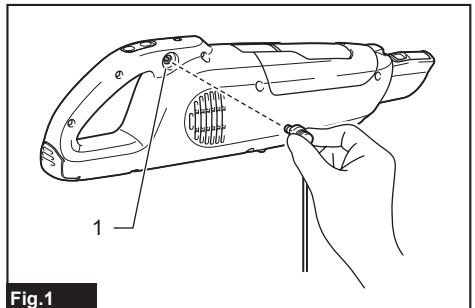

Fig.1

► 1. Charging connector

The battery power lamp lights up and the charging starts. The light goes out after the charging is complete. For more details, refer to the instruction manual of battery charger.

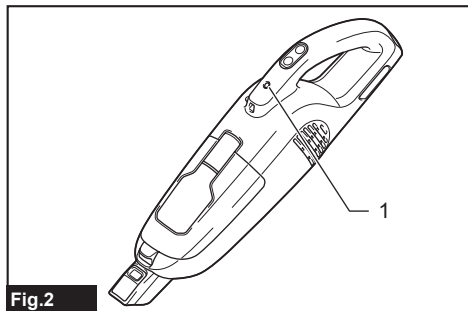

Fig.2

► 1. Battery power lamp

NOTICE: The battery power lamp blinks and the battery cannot be charged if the battery or cleaner is exposed to extreme temperatures.

NOTE: The cleaner cannot be controlled while being charged. To start the cleaner, unplug the charger from the power source, disconnect the charging plug from the cleaner, and then push the ON/speed change button.

NOTE: Under the following conditions, the battery is about to reach its end of life (or damaged/malfunctioned). Unplug the charger from the power supply, then replace the battery.

- The battery power lamp goes out shortly after you begin to charge the cleaner.
- The cleaner works only for a period shorter than half of the normal operating time after the battery has been fully charged.

NOTE: The battery can be recharged up to approximately 500 times. The rechargeable times vary depending on the conditions under which the battery has been charged and discharged.

Switch action

CAUTION: Always switch off the cleaner after each use to prevent damage to the cleaner and to extend the service life of the batteries.

To start the cleaner, simply push the ON/speed change button. To switch off, push the OFF button. You can change the cleaner speed in three steps by pushing the ON/speed change button. The first push on this button is for high speed mode, the second push for max speed mode and the third push for normal speed mode. Each push on this button repeats the high/max/normal speed cycle alternatively.

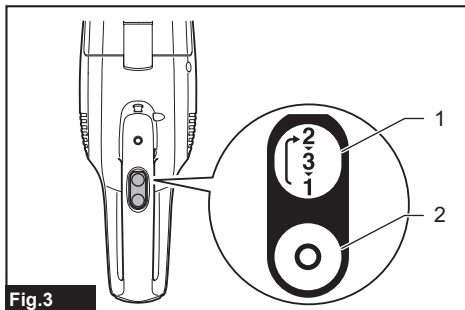

Fig.3

► 1. ON/speed change button 2. OFF button

Battery power lamp

When the remaining battery capacity gets low, the battery power lamp blinks.

When the remaining battery capacity gets much lower, the cleaner stops and the battery power lamp lights up about 10 seconds. At this time, charge the battery. Also when the battery gets overloaded or overheated, the cleaner stops and the battery power lamp lights up about 10 seconds. The cleaner does not actuate during the lamp on.

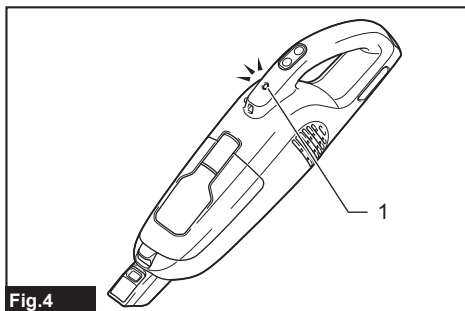

Fig.4

► 1. Battery power lamp

NOTE: The time at which the battery power lamp start blinking or lighting up depends on the temperature at work place and the battery conditions.

Lighting up the lamp

CAUTION: Do not look in the light or see the source of light directly.

To turn on the lamp, push the ON/speed change button. Push the OFF button to turn off the lamp. During the cleaner actuating, the lamp turns on.

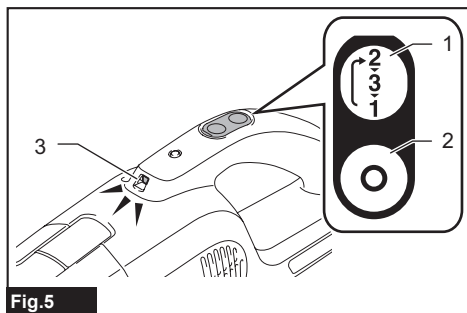

Fig.5

► 1. ON/speed change button 2. OFF button 3. Lamp

ASSEMBLY

CAUTION: Always be sure that the appliance is switched off before carrying out any work on the appliance.

Dust bag and paper filter

Install either dust bag or paper filter before using cleaner.

Use the dust stopper when installing either dust bag or paper filter.

Dust bag are usable many times repeatedly by cleaning it out.

Paper filter is a throw-away type. Throw away the entire paper filter without emptying when it has become full.

NOTICE: To prevent dust from getting into the motor:

- Make sure that the dust bag or paper filter is installed before use.
- Insert the dust stopper together with the dust bag or paper filter all the way into the slots when installing them.
- Do not use a broken or ripped bag.

Otherwise the motor may be broken.

NOTICE: Do not fold the cardboard at its opening when installing the paper filter.

NOTICE: Never throw away the dust stopper because it needs to be used repeatedly whenever either the dust bag or the paper filter is used.

NOTICE: The paper filter for the cleaner is an important component for maintaining the cleaner performance. Using other than the genuine paper filter may cause smokes or ignition.

NOTE: When the dust bag or the paper filter is not installed in the cleaner, the front cover does not close completely.

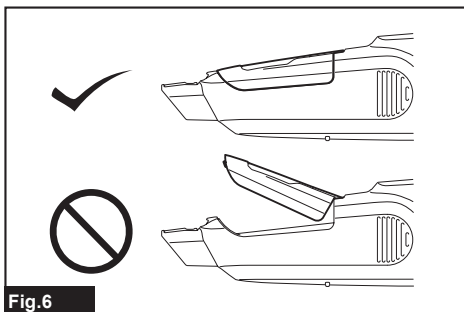

Fig.6

Installing dust bag

Use the dust stopper when installing dust bag. Be careful not to take the upper side for the lower side by mistake because they are different each other.

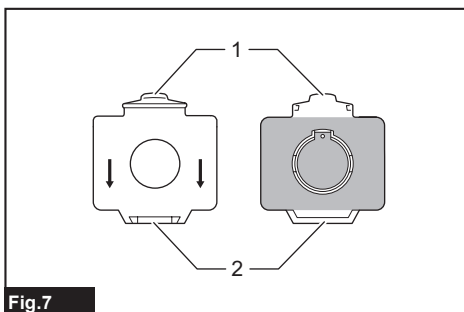

Fig.7

► 1. Upper side of dust stopper 2. Lower side of dust stopper

1. Insert the protrusion of the dust bag into the lower groove on the dust stopper as shown in the figure.

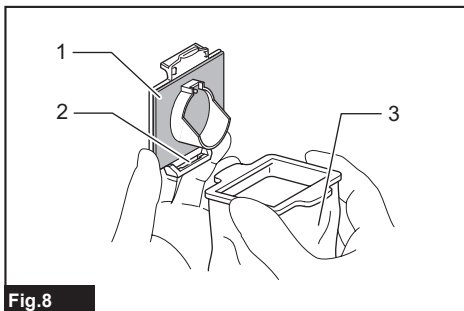

Fig.8

► 1. Dust stopper 2. Lower groove 3. Dust bag

2. There is no distinction between the upper and lower sides of the dust bag. You may insert its protrusion of either side into the lower groove of the dust stopper.

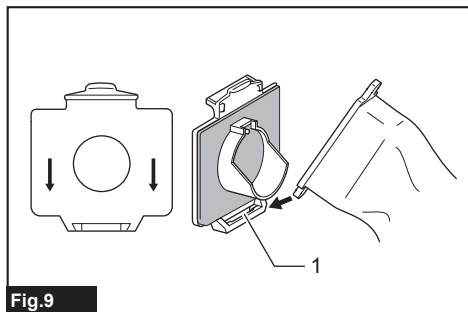

Fig.9

► 1. Lower groove

3. Overlap the frame of dust stopper with that of the dust bag.

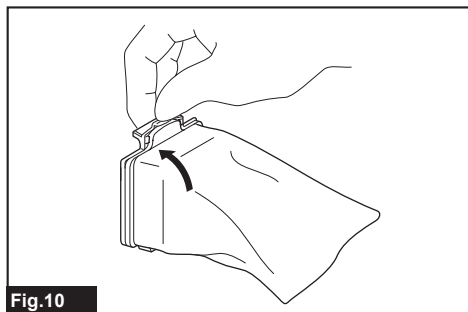

Fig.10

4. Place the dust stopper and the dust bag together into the cleaner cavity in the same direction of arrow on the dust stopper. Insert them all the way into the slots in the cleaner cavity.

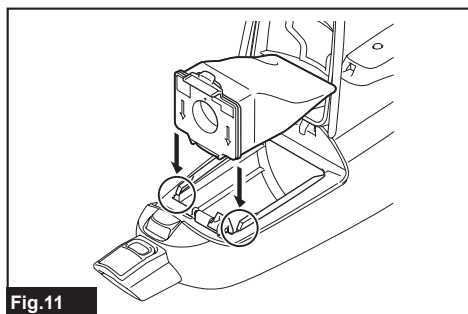

Fig.11

5. Spread the cloth part of the dust bag inside the cleaner.

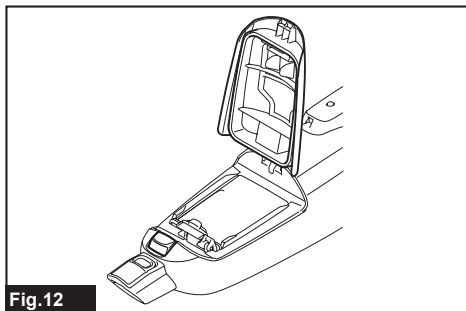

Fig.12

6. Close the front cover completely.

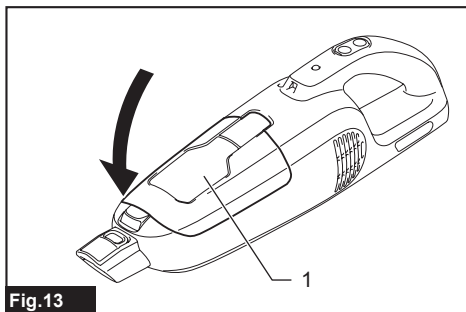

Fig.13

► 1. Front cover

Installing the paper filter

Use the dust stopper also when installing paper filter. Be careful not to take the upper side for the lower side by mistake because they are different each other.

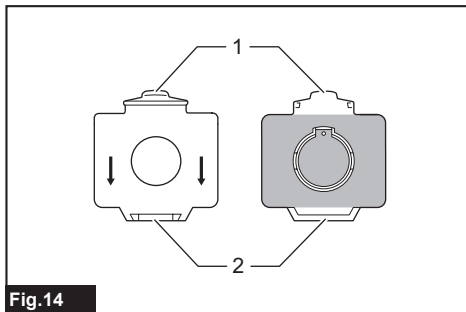

Fig.14

► 1. Upper side of dust stopper 2. Lower side of dust stopper

1. Unfold the entrance of the paper filter before setting it on the dust stopper.

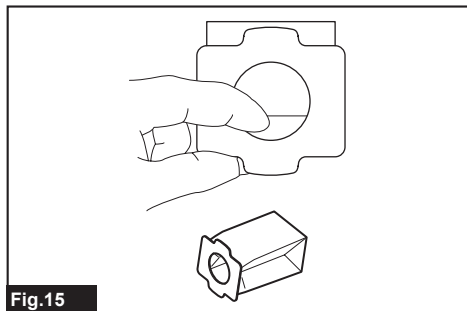

Fig.15

2. Insert the protrusion of the paper filter into the lower groove on the dust stopper as shown in the figure.

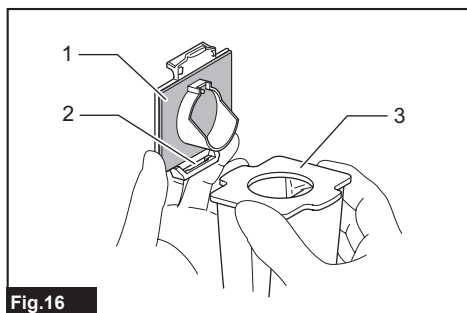

Fig.16

- 1. Dust stopper 2. Lower groove 3. Paper filter

3. There is no distinction between the upper and lower sides of the paper filter. You may insert its protrusion of any side into the lower groove of the dust stopper.

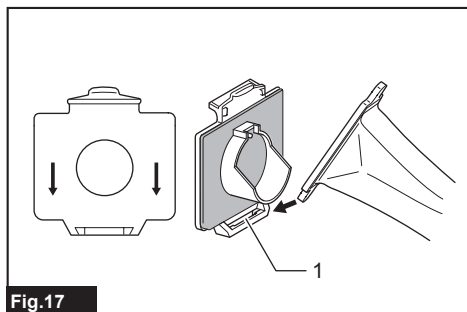

Fig.17

- 1. Lower groove

4. Overlap the frame of dust stopper with that of the paper filter.

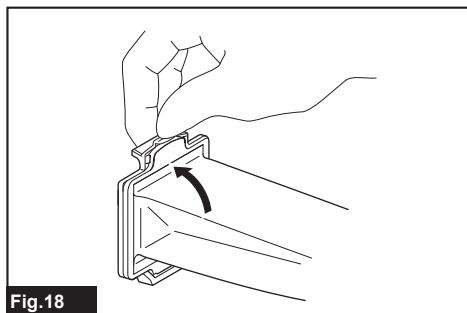

Fig.18

5. Place the dust stopper and the paper filter together into the cleaner cavity in the same direction of arrow on the dust stopper. Insert them all the way into the slots in the cleaner cavity.

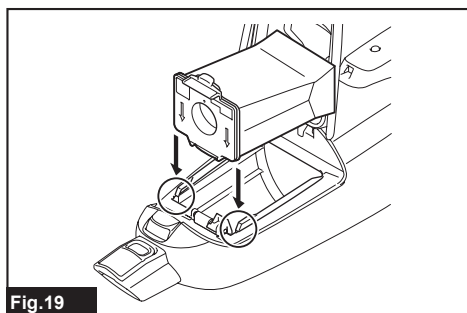

Fig.19

6. Spread the container part of the paper filter inside the cleaner.

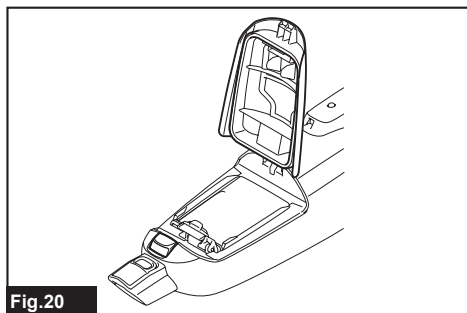

Fig.20

7. Close the front cover completely.

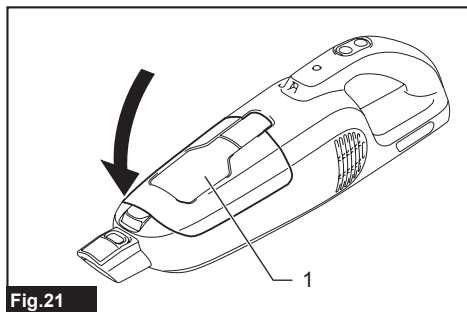

Fig.21

- 1. Front cover

OPERATION

CAUTION: Do not move your face close to the air vent when operating the cleaner. If foreign objects are blown into eyes, it may result in personal injury.

Installing or removing the cleaner attachment

CAUTION: After installing an attachment, check if it is securely installed. If the attachment is installed imperfectly, it may come off and cause personal injury.

CAUTION: Be careful not to hit your hand on the wall etc. when removing the attachment.

When using attachment with lock function

To install an attachment, insert it to the suction inlet of the cleaner until it clicks. Make sure that the attachment is locked.

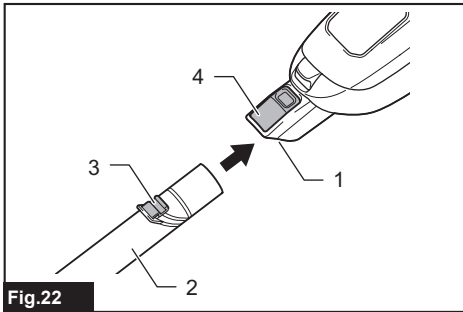

Fig.22

- ▶ 1. Suction inlet 2. Attachment with lock function
- ▶ 3. Hook 4. Release button

NOTE: When installing the attachment with lock function, be sure to align the release button with the hook on the attachment. If they are not aligned, the attachment will not be locked and may come off from the cleaner.

To remove the attachment, pull it while pushing the release button.

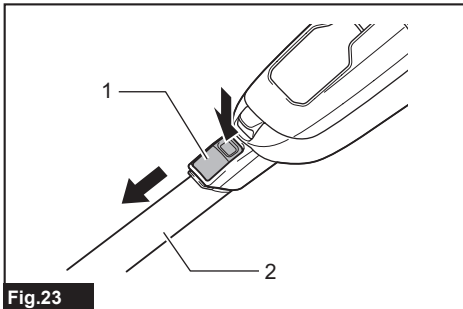

Fig.23

- ▶ 1. Release button 2. Attachment with lock function

When using attachment without lock function

CAUTION: To install an attachment without lock function, twist and insert it in direction of the arrow to secure the connection during use. To remove the attachment, twist and extract it also in direction of the arrow.

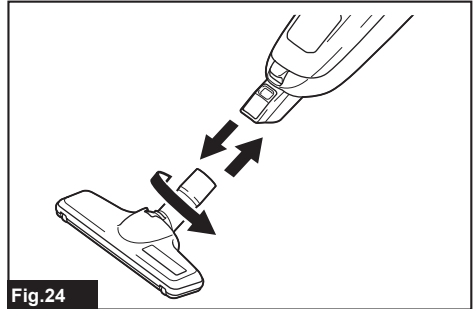

Fig.24

Cleaning (Suction)

Nozzle

Attach the nozzle to clean off tables, desks, furniture, etc. The nozzle slips on easily.

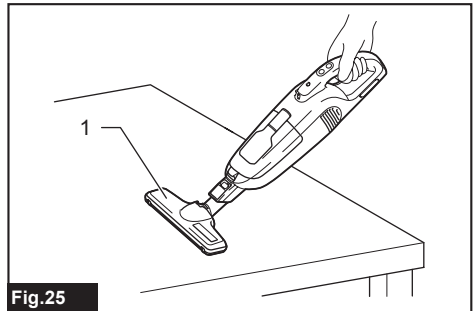

Fig.25

- ▶ 1. Nozzle

Nozzle + Extension wand (Straight pipe)

The extension wand fits in between the nozzle and the cleaner itself. This arrangement is convenient for cleaning a floor in a standing position.

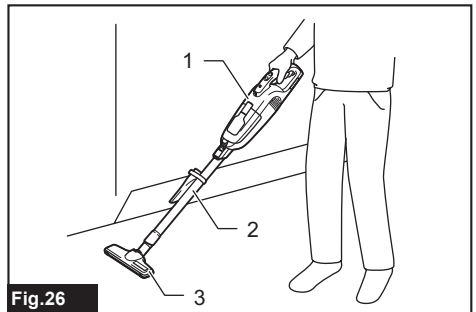

Fig.26

- ▶ 1. Cleaner body 2. Extension wand 3. Nozzle

Corner nozzle

Fit on the corner nozzle for cleaning corners and crevices of a car seat or furniture.

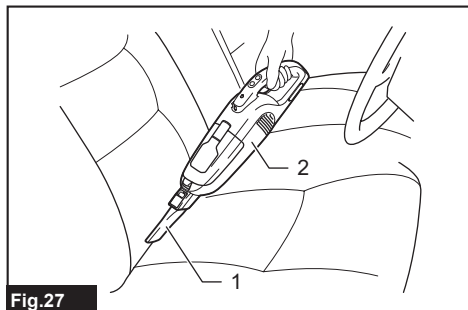

Fig.27

► 1. Corner nozzle 2. Cleaner body

Corner nozzle + Extension wand (Straight pipe)

In tight quarters where the cleaner itself cannot squeeze in, or in high places hard to reach, use this arrangement.

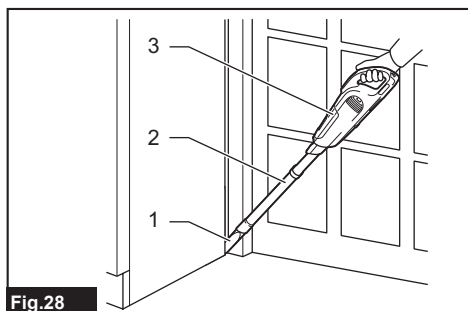

Fig.28

► 1. Corner nozzle 2. Extension wand 3. Cleaner body

Cleaning without nozzle

You can pick up powder and dust without nozzle.

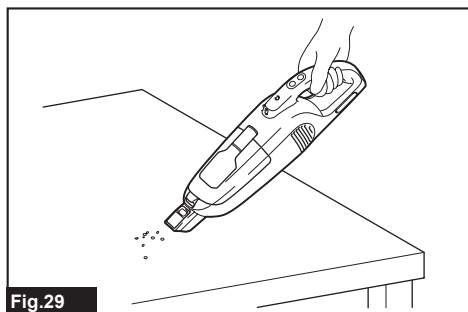

Fig.29

For picking up dust on a floor in a standing position, it is convenient to attach the extension wand to the cleaner.

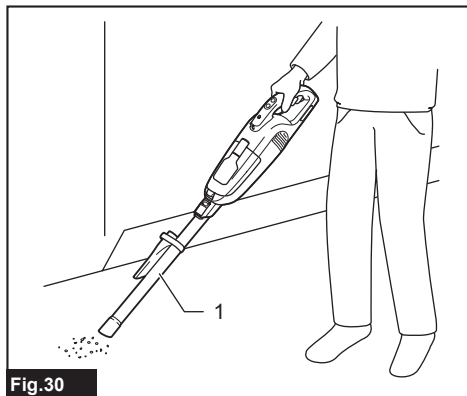

Fig.30

► 1. Extension wand

Disposing of dust

CAUTION: Empty the cleaner before it becomes too full, or the suction force weakens.

CAUTION: When closing the front cover, be careful not to pinch your fingers.

NOTICE: Never throw away the dust stopper because it should be used whenever either the dust bag or the paper filter is used.

NOTICE: When the dust bag/paper filter is not inside of the cleaner, the front cover does not close completely. Do not force to close the front cover. It may result in deforming or breakage of the cleaner.

NOTICE: When disposing of dust, also clean the room for the dust bag/paper filter. The remaining dust and dirt in the room may cause the sponge filter to be clogged or the motor to be damaged.

1. Push the button to open the front cover. Opening it until a click is heard allows a positive stop at that position.

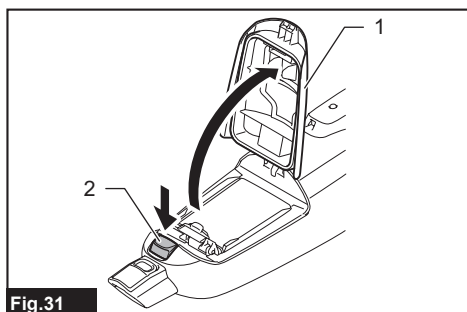

Fig.31

► 1. Front cover 2. Button

2. Pull out both the orange-colored dust stopper and dust bag/paper filter together at the same time.

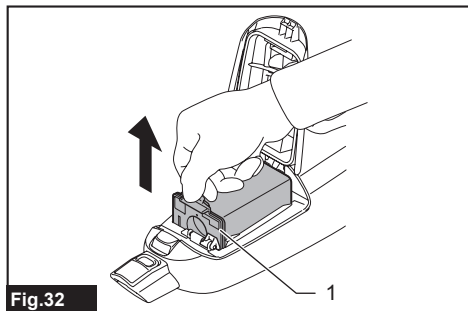

Fig.32

- ▶ 1. Dust stopper

3. Perform the procedures below depending on the dust container type:

When using the dust bag

Remove the dust stopper and empty the dust bag.

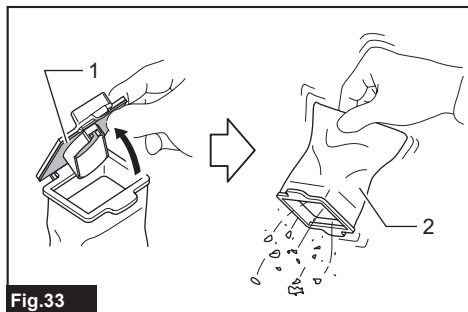

Fig.33

- ▶ 1. Dust stopper 2. Dust bag

When using the paper filter

Remove the dust stopper and dispose of the paper filter.

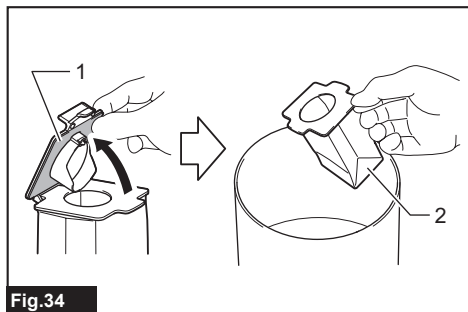

Fig.34

- ▶ 1. Dust stopper 2. Paper filter

4. Place the dust bag/new paper filter and dust stopper together into the cleaner and close the front cover.

NOTE: The cleaner is constructed in such a way that the front cover comes off when trying to force the front cover open at the angle of more than 90°. If the front cover comes off, insert it into the front cover joint in place.

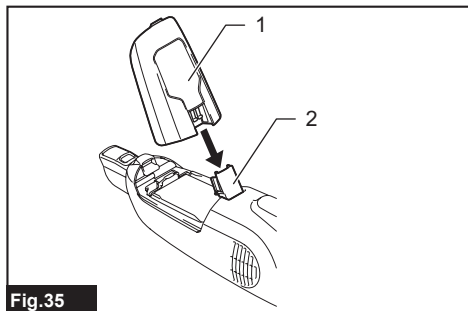

Fig.35

- ▶ 1. Front cover 2. Front cover joint

MAINTENANCE

CAUTION: Always be sure that the appliance is switched off before attempting to perform inspection or maintenance.

To maintain product SAFETY and RELIABILITY, repairs, any other maintenance or adjustment should be performed by Makita Authorized or Factory Service Centers, always using Makita replacement parts.

NOTICE: Never use gasoline, benzine, thinner, alcohol or the like. Discoloration, deformation or cracks may result.

After use

When storing or charging the cleaner, lock the nozzle head, and hang it from a hook available in the market.

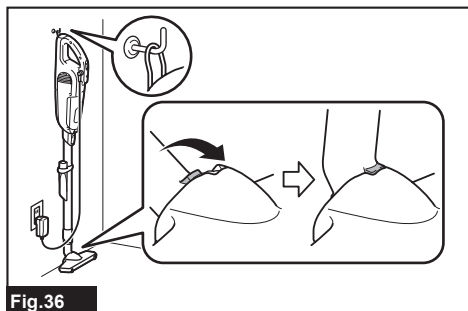

Fig.36

CAUTION: Putting the cleaner against the wall without any other support may cause the cleaner to fall down and be damaged.

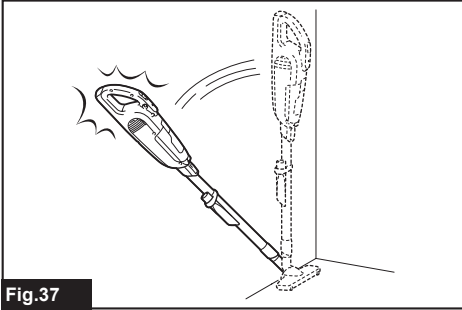

Fig.37

Cleaning

Cleaner body

From time to time wipe off the outside (cleaner body) of the cleaner using a cloth dampened in soapy water. Clean out also the suction opening, dust bag/paper filter mounting area and the dust stopper.

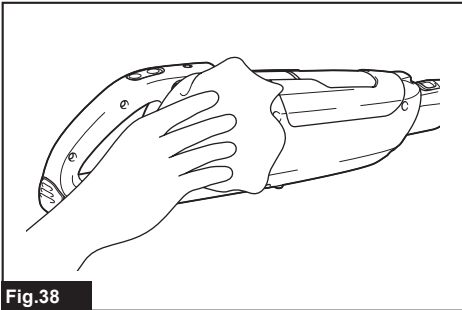

Fig.38

Dust stopper

Wipe dust off from the dust stopper. Remove dust and dirt on the sponge part by lightly tapping it.

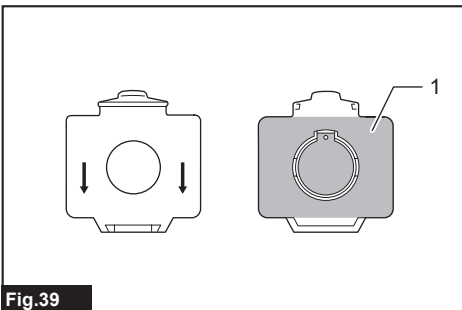

Fig.39

► 1. Sponge part

Dust bag

Wash the dust bag in soapy water when it is clogged with dust and the cleaner power becomes weak. Dry it out thoroughly before use. An insufficiently dried bag may cause poor suction and shorten the service life of the motor.

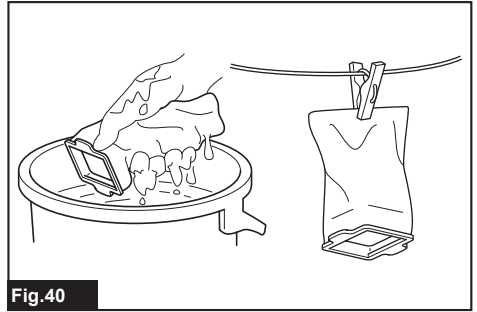

Fig.40

NOTE: Paper filter is a throw-away type.

When the sponge filter is clogged with dust, remove it from the cleaner and then wipe it off or wash in water.

Removing and installing the sponge filter

CAUTION: After cleaning sponge filter, be sure to install it on the cleaner. If washed in water, dry it up before installing. An insufficiently dried sponge filter may shorten the service life of the motor.

To remove the sponge filter, remove the dust bag or paper filter and then pinch and take the sponge filter out.

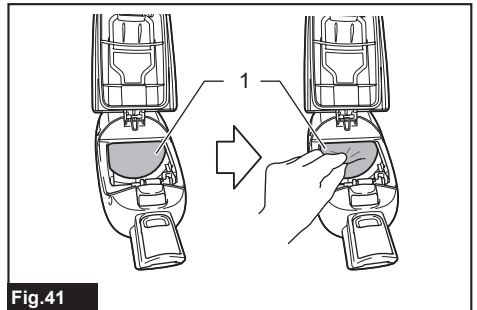

Fig.41

► 1. Sponge filter

To install the filter, press in the whole edge of the sponge filter against the recessed wall inside the dust bag/paper filter mounting area.

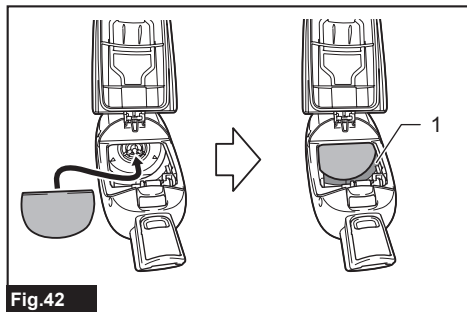

Fig.42

► 1. Recessed wall

The nozzle cleaning

(country specific)

When the nozzle brush gets dusty, clean up the dust with adhesive tape.

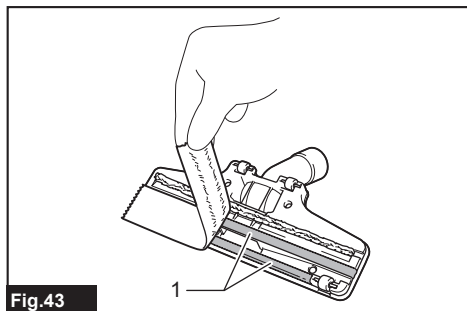

Fig.43

► 1. Brush

Wall mount for cordless cleaner

Optional accessory

NOTE: The screw to mount the holder is not included. Prepare a screw which fits with the material to screw into.

Attach the wall mount for cordless cleaner to a hard wooden wall, beam or column, where the wall mount for cordless cleaner can be firmly secured. Always be sure that the wall mount for cordless cleaner is securely attached before hanging the cleaner.

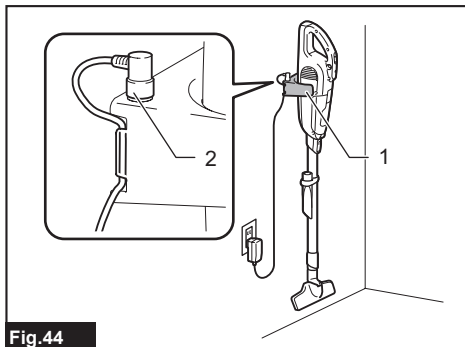

Fig.44

► 1. Wall mount for cordless cleaner 2. Plug

CAUTION: Do not hang the cleaner to the wall mount violently or hang other appliances than the cleaner.

NOTE: When you don't charge the cleaner, the plug can be stored on the wall mount for cordless cleaner as illustrated.

Troubleshooting

Before asking for repairs, check the following points.

Symptom	Area to be investigated	Fixing method
Weak suction power	Is dust bag or paper filter full of dust ?	Empty dust bag or paper filter.
	Is dust bag clogged ?	Dust down or wash the dust bag.
	Is paper filter clogged ?	Replace paper filter.
	Is the battery cartridge discharged?	Charge the battery cartridge.
Not working	Is the battery cartridge discharged?	Charge the battery cartridge.
Dust case cover does not close	Is dust bag or paper filter set ?	Set dust bag or paper filter.

NOTICE: Do not attempt to repair cleaner by yourself.

Disposing cleaner

A Li-ion battery is built in this cleaner. Always remove it before disposing of the cleaner.

Removing built-in battery

⚠ CAUTION: Do not touch the terminals with any conductive material.

⚠ CAUTION: Avoid storing battery unit in a container with other metal objects such as nails, coins, etc.

⚠ CAUTION: Do not expose battery unit to water or rain.

⚠ CAUTION: Do not disassemble or alter battery unit.

⚠ CAUTION: The cleaner must be disconnected from the supply mains when removing the battery.

1. To remove the rear cover, push it in the direction of the arrow.

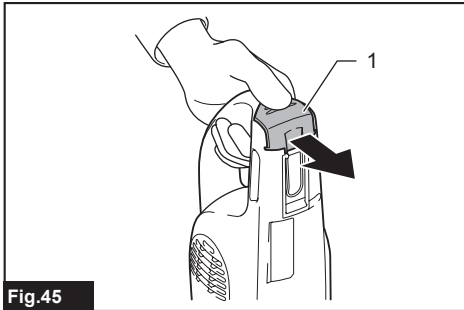

Fig.45

- ▶ 1. Rear cover

2. Slide the built-in battery halfway. Disconnect the lead wires from the battery by slightly moving back the battery while pressing the connector in the direction of arrow as shown in the figure.

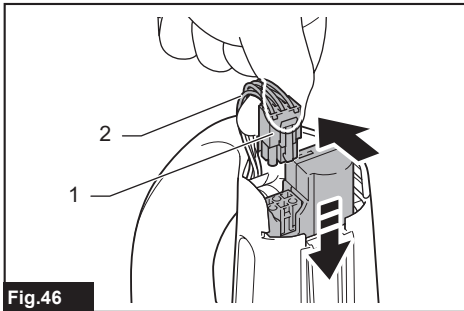

Fig.46

- ▶ 1. Connector 2. Lead wires

3. Then slide the battery unit out completely.

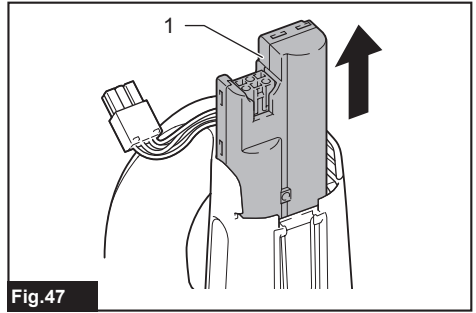

Fig.47

- ▶ 1. Battery unit

4. Put the removed battery unit in a carton box so that it is not circuit-shorted.

Installing replacement battery

To install the replacement battery, follow the removal procedure in reverse.

⚠ CAUTION: Route the lead so that it is completely stored inside the cleaner before putting the rear cover back in the original position. Failure to do this may damage the lead.

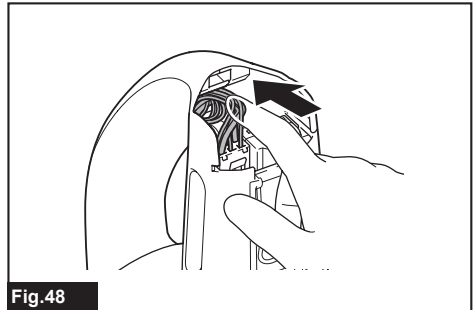

Fig.48

After installing the battery (see "SPECIFICATIONS"), charge the battery before use.

CYCLONE ATTACHMENT

Optional accessory

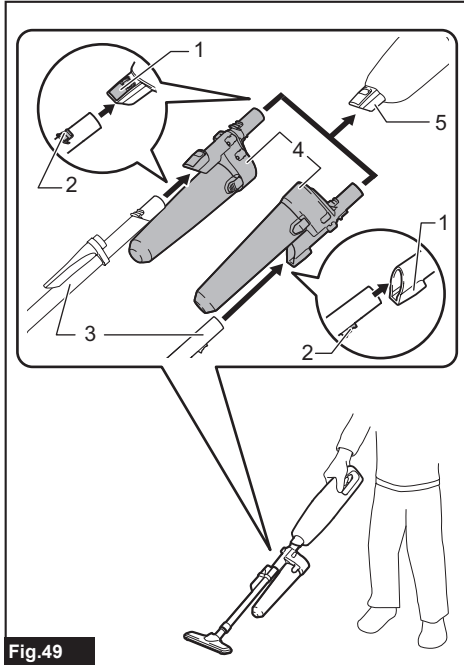

Fig.49

- ▶ 1. Release button 2. Hook 3. Straight pipe
- 4. Cyclone attachment 5. Suction inlet

About the cyclone attachment

Using the cleaner with the cyclone attachment installed reduces the amount of dust that enters the dust bag, which helps to prevent the suction force from weakening. In addition, cleaning after use is also simple.

CAUTION: Always be sure that the cleaner is switched off before carrying out any work on the cleaner. Unintentional starting may result in injury.

CAUTION: Clean the mesh filter of the cyclone attachment and the dust bag of the cleaner unit when they become clogged. Continued use in the clogged condition may result in heating or smoke.

NOTICE: When the cyclone attachment is attached, do not use the cleaner in the horizontal or upward facing condition. Doing so may cause the mesh filter to become clogged.

NOTICE: Always use the cleaner with the dust bag installed, even when using the cyclone attachment. Using the cleaner without the dust bag installed may result in a motor malfunction.

NOTE: Check that the cyclone attachment, cleaner, and straight pipe are locked properly before use.

NOTE: Empty the dust case of the cyclone attachment and the dust bag of the cleaner when dust has accumulated. Continued use will result in weakened suction force.

NOTE: You can also use the cyclone attachment without lock function.

NOTE: To install or remove the cyclone attachment, refer to the section "Installing or removing the cleaner attachment".

Disposing of dust

When dust has accumulated up to the full line of the dust case, follow the procedure below and dispose of the dust.

1. Hold the dust case firmly, press and hold the two buttons, and remove the dust case.

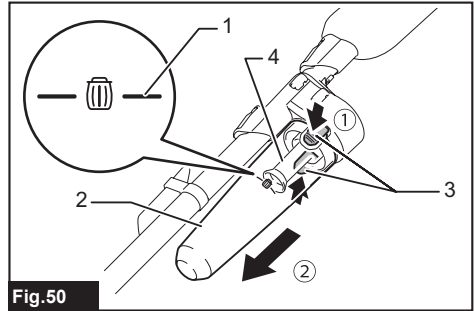

Fig.50

- ▶ 1. Full line 2. Dust case 3. Button (two locations)
- 4. Mesh filter

2. Dispose of the dust inside the dust case and remove any dust and powder adhered to the surface of the mesh filter.

3. Insert the dust case all the way until the two buttons lock with a click.

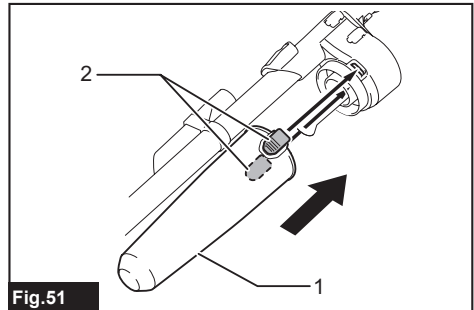

Fig.51

- ▶ 1. Dust case 2. Button (two locations)

NOTE: Check that the cyclone attachment, cleaner, and straight pipe are locked properly before restarting operation.

NOTE: If the suction force does not recover even after disposing of the dust and cleaning the mesh filter, check whether dust has accumulated in the dust bag of the cleaner or clogging has occurred.

NOTE: The dust may fly up when disposing from the cyclone attachment. Be careful not to let dust get into your eyes.

Cleaning

When the dust case becomes dirty or the mesh filter is clogged, remove and wash them with water. (Refer to "Disposing of dust" for the removal procedure.)

Dry the parts thoroughly before reinstallation and use.

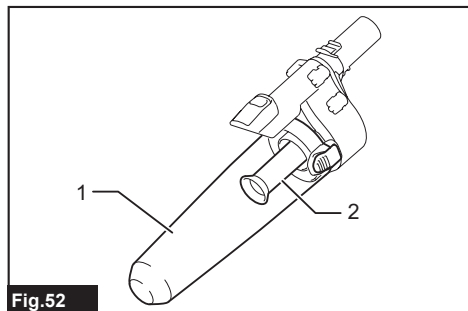

Fig. 52

► 1. Dust case 2. Mesh filter

When the mesh filter gets dirty badly, clean it in the following procedures.

1. Turn the mesh filter counterclockwise and remove it while the hooks are unlocked.

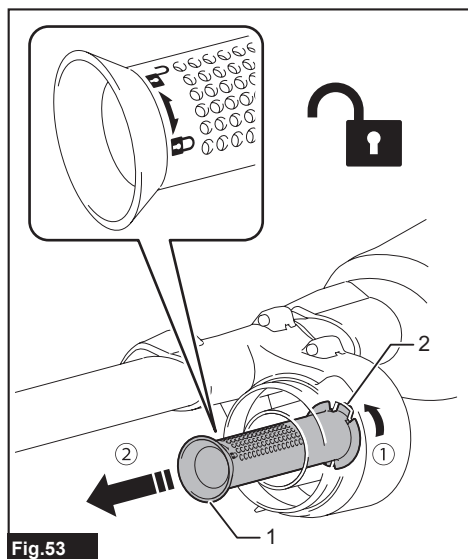

Fig. 53

► 1. Mesh filter 2. Hook

2. Remove the dust on the mesh filter and then wash it with water. After that, dry it thoroughly.

3. Insert the mesh filter into the base while the hooks are aligned with the port. Turn the mesh filter clockwise until the hooks are locked with a click. Make sure that the mesh filter is installed securely.

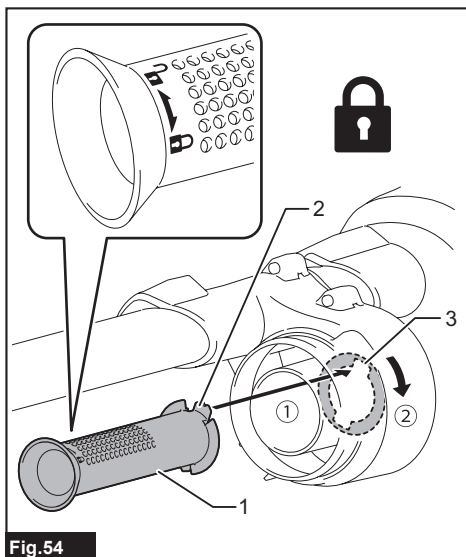

Fig. 54

► 1. Mesh filter 2. Hook 3. Port

OPTIONAL ACCESSORIES

CAUTION: These accessories or attachments are recommended for use with your Makita appliance specified in this manual. The use of any other accessories or attachments might present a risk of injury to persons. Only use accessory or attachment for its stated purpose.

If you need any assistance for more details regarding these accessories, ask your local Makita Service Center.

- Extension wand (Straight pipe)
- Nozzle
- Nozzle for carpet
- Shelf brush
- Corner nozzle
- Round brush
- Flexible hose
- Paper filter
- Wall mount for cordless cleaner
- Replacement battery
- Free nozzle
- Seat nozzle
- Crevice nozzle
- Cyclone attachment

NOTE: Some items in the list may be included in the appliance package as standard accessories. They may differ from country to country.

Makita Europe N.V. Jan-Baptist Vinkstraat 2,
3070 Kortenberg, Belgium

Makita Corporation 3-11-8, Sumiyoshi-cho,
Anjo, Aichi 446-8502 Japan

www.makita.com

885813B224 EN 20230117
