

Accessories

Guide bar / Saw chain / Guide bar cover / File diameter / Drive sprocket

*Micro-Lite

**Speedcut Nano



Drive sprocket



Cutter type:
MC: Micro chisel,
CC: Chamfer chisel

Guide bar		Saw chain						Bar cover	Round file diameter	Drive sprocket	
Bar length	Part No. Sprocket nose bar	No. of drive links	Gauge	Pitch	Cutter type		Saw chain Part No.	Part No.	Pitch/ No. of teeth	Part No.	
30cm/12"	*191G15-1	46	1.1mm/.043"	3/8"	90PX	CC	191H01-8	419288-5	4.5mm	3/8" / 6	191V90-7
30cm/12"	191G23-2	46	1.3mm/.050"	3/8"	91PX	CC	191H10-7	419288-5	4.0mm	3/8" / 6	191V90-7
30cm/12"	**191T86-6	51	1.1mm/.043"	.325	80TXL	MC	191T90-5	419288-5	4.0mm	.325" / 7	191V91-5
35cm/14"	*191G16-9	52	1.1mm/.043"	3/8"	90PX	CC	191H02-6	419288-5	4.5mm	3/8" / 6	191V90-7
35cm/14"	191G24-0	52	1.3mm/.050"	3/8"	91PX	CC	191H11-5	419288-5	4.0mm	3/8" / 6	191V90-7
35cm/14"	**191T87-4	59	1.1mm/.043"	.325	80TXL	MC	191T91-3	419288-5	4.0mm	.325" / 7	191V91-5
40cm/16"	*191G17-7	56	1.1mm/.043"	3/8"	90PX	CC	191H03-4	419242-9	4.5mm	3/8" / 6	191V90-7
40cm/16"	191G25-8	56	1.3mm/.050"	3/8"	91PX	CC	191H12-3	419242-9	4.0mm	3/8" / 6	191V90-7
40cm/16"	**191T88-2	64	1.1mm/.043"	.325	80TXL	MC	191T92-1	419242-9	4.0mm	.325" / 7	191V91-5
45cm/18"	191G26-6	62	1.3mm/.050"	3/8"	91PX	CC	191H13-1	419242-9	4.0mm	3/8" / 6	191V90-7
45cm/18"	**191X03-0	70	1.1mm/.043"	.325	80TXL	MC	191X04-8	419242-9	4.0mm	.325" / 7	191V91-5

Round file and File holder

The file can be guided more easily if a file holder is employed. The file holder has markings for the correct sharpening angle of 30° (align the markings parallel to the saw chain) and limits the depth of penetration (to 4/5 of the file diameter).

Size	Saw chain type	Round file		Round file and File holder	
		Q'ty	Part No.	Part No.	Part No.
4mm	91PX, 80TXL	1	953 003 090	195089-2 198457-8 D-70948	
		2	D-67359		
		12	D-67356		
4.5mm	90PX	1	953 003 100	195923-6 D-70954	
		2	D-67371		
		12	D-67387		

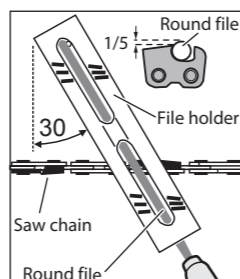

Chain oil & BIOTOP Chain oil

Chain oil		BIOTOP Chain oil	
Size	Part No.	Size	Part No.
100ml	182229-1	1L	980 008 610
1L	988 002 656	5L	980 008 611
5L	988 002 658		

Flat file



Q'ty	Part No.
1	953 003 060
1	D-67452
12	D-67468

File handle

For flat file and round file



Q'ty	Part No.
1	953 004 010
1	D-67496
50	D-67505



Depth gauge jointer

After sharpening the chain, check the height of the depth gauge using the chain gauge tool.



Part No.
953 100 090, D-67474

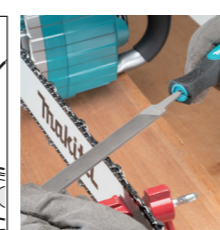
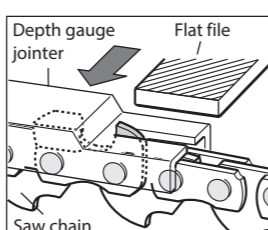

Charging Time

Battery	Fast Charging	
	DC40RA	DC40RC
BL4040 4.0Ah	45 min	67 min
*BL4050F 5.0Ah	50 min	85 min
*BL4080F 8.0Ah	76 min	170 min

*1 Recommended battery

Cordless Chain Saw

UC010G/ UC011G/ UC012G/ UC013G/ UC020G (Captive nuts type)	
300mm (12")/ 350mm (14")/ 400mm (16")/ 450mm (18")/ Motor Unit Only	
UC014G/ UC015G/ UC016G/ UC017G (Tool-less chain adjustment type)	
300mm (12")/ 350mm (14")/ 400mm (16")/ 450mm (18")	
	Variable Speed
	Brake
	Automatic Oiling
	Chain Brake
Guide Bar Length	UC010G/ UC014G: 300 mm (12"), UC011G/ UC15G: 350 mm (14"), UC012G/ UC16G: 400 mm (16"), UC013G/ UC17G: 450 mm (18"), UC020G: Motor Unit Only
Chain Pitch / Chain Gauge	UC010G-UC017G: 3/8"/1.1or 1.3 mm (.043"/or .050"), 0.325"/1.1mm (.043"), UC020G: 3/8"/0-25.5 m/s (0-1,530 m/min)
Chain Speed	260 mL
Chain Oil Tank Volume	104dB(A)
Sound Power Level	Vibration Level (Front/ Rear)
104dB(A)	3, 4 / 4.4 m/s ² (saw chain: 90PX)
Dimensions (L x W x H)	UC010G-UC013G, UC020G w/o guide bar: 445 x 230 x 275 mm (17-1/2 x 9 x 10-7/8")
Overall length	UC014G-UC017G w/o guide bar: 445 x 234 x 275 mm (17-1/2 x 9-1/4 x 10-7/8")
(Saw chain with 90PX)	UC010G/ UC014G: 708 mm (27-7/8"), UC011G/ UC15G: 765 mm (30-1/8")
Net weight	UC012G/ UC16G: 801 mm (31-1/2"), UC013G/ UC17G: 858 mm (33-3/4")
	UC010G-UC013G: 6.1 - 7.4kg (13.4 - 16.3lbs.), UC014G-UC017G: 6.2 - 7.5kg (13.7 - 16.5lbs.), UC020G: 6.2 - 7.4kg (13.7 - 16.3lbs.)

Standard Equipment :

UC010G-UC017G: Saw chain, Guide bar, Guide Bar Cover, Chain oil (country-specific), Round file (country-specific), Wrench, Battery, Charger, Safety goggles (country-specific) UC020G: Chain oil (country-specific), Round file (country-specific), Wrench, Battery, Charger, Safety goggles (country-specific)

The weight may differ depending on the attachment(s), including the battery cartridge. The lightest and heaviest combination, according to EPTA-Procedure 01/2014, are shown in the table. Items of standard equipment and specifications may vary by country or area.

Makita Corporation

3-11-8 Sumiyoshi-cho, Anjo, Aichi, 446-8502 Japan

PRINTED IN JAPAN 202203



photo: UC012G

Net weight (tool only)
4.5 kg

Max Chain Speed
25.5 m/s

Captive nuts type

- UC010G: 300mm (12")
- UC011G: 350mm (14")
- UC012G: 400mm (16")
- UC013G: 450mm (18")

photo: UC012G

Tool-less chain adjustment type

- UC014G: 300mm (12")
- UC015G: 350mm (14")
- UC016G: 400mm (16")
- UC017G: 450mm (18")

photo: UC016G

Motor Unit Only

- UC020G
- User can self select Guide bar



High operating efficiency

BL MOTOR

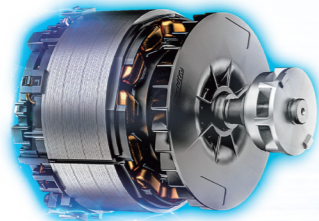

Powerful & durable

High power Li-ion battery



Metal handle

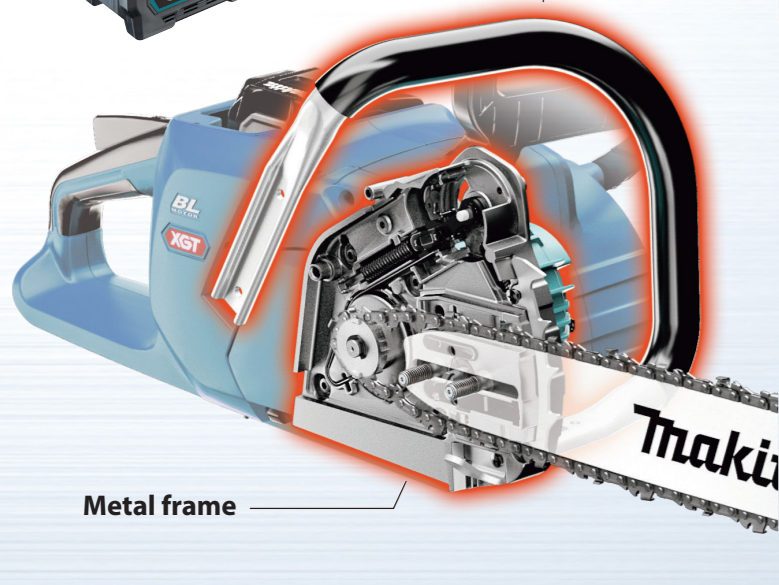

Metal frame



Excellent tool balance



Slim body

42cc engine tool

Center of gravity



WG / IPX4
WET GUARD

High water-resistance allows to operate the machine even if it is wet with water.

High Speed cutting Compared to predecessor model

80% up

- φ300mm cedar timber
- Guide bar/ Saw chain: 400mm/ 80TXL
- Battery : BL4050F

Cutting work amount

Work volume on a single full battery charge

About **35** cuts

- φ300mm cedar timber
- Guide bar/ Saw chain: 400mm/ 80TXL
- Battery : BL4050F



High performance in close-to-the-ground cutting



Metal spike bar



Large oil tank cap allows for easy chain oil filling.



Chain tensioning screw



Captive nuts prevent loss of nut when removing a sprocket cover to replace a guide bar or a saw chain.



Tool-less chain adjustment Easier saw chain tightening Higher tightening torque

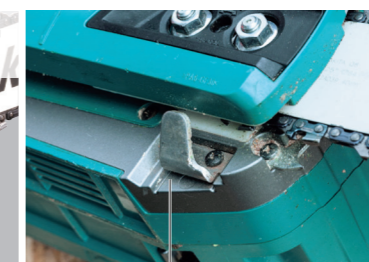

Metal chain catcher



Variable speed trigger switch



Main power switch allows for easy chain oil filling.